

- NOTES, UNLESS OTHERWISE SPECIFIED:
1. ALL DIMENSIONS ARE IN DECIMAL INCHES.
  2. REMOVE ALL BURRS & SHARP EDGES.
  3. REMOVE ALL TOOLING MARKS.
  4. DIMENSIONS & TOLERANCES SHALL BE HELD AFTER PLATING OR FINISH.

REVISIONS				
ECR #	REV	DESCRIPTION	DATE	APPROVED
1807	02	ADDITION OF DYNO LOCATION PAGE	01/07/04	JFE
1878	03	ADDITION OF DYNO EXTENDED RETARDER PIT & NOTES	02/25/04	JFE

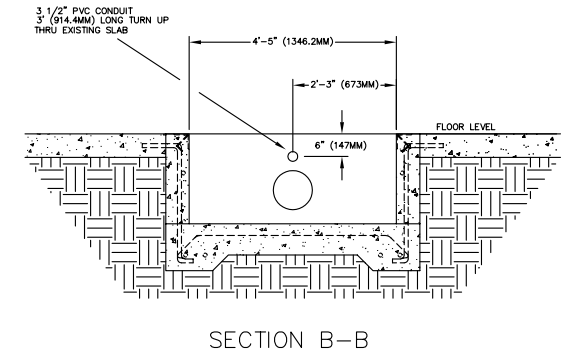
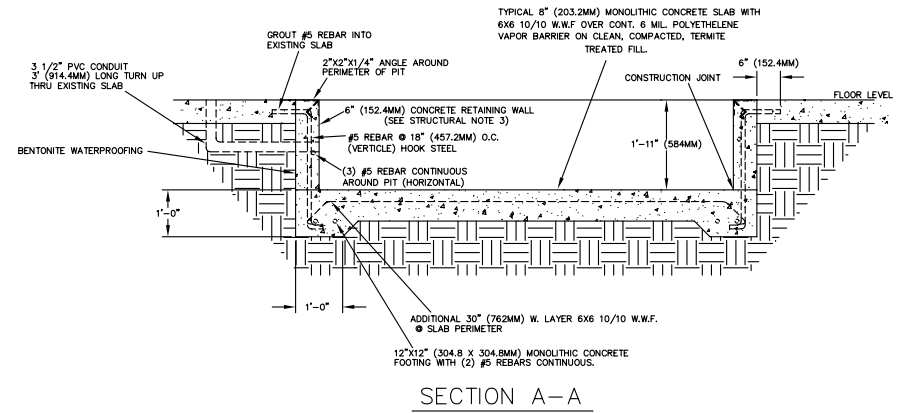
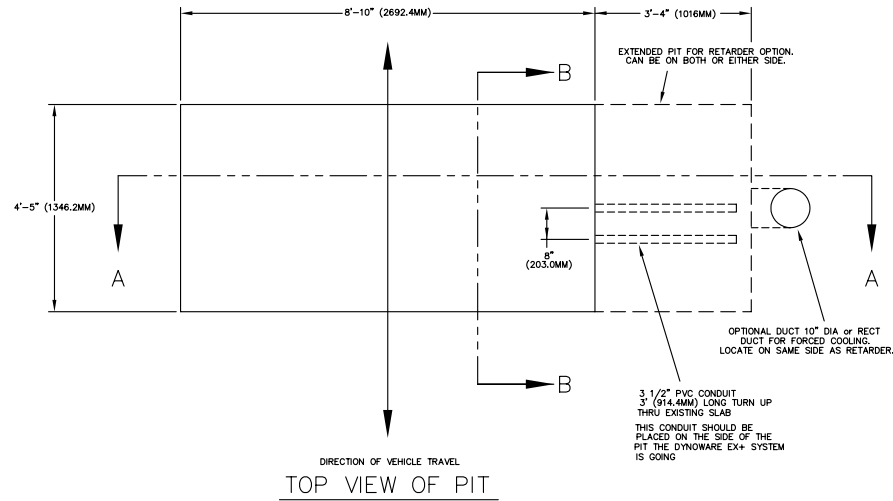

NOTES:

1. ALL DIMENSIONS ARE NOMINAL TO FACE OF MASONRY OR TO FACE OF METAL STUD.
2. ALL WORK SHALL BE IN ACCORDANCE WITH LOCAL AND STATE AND OR ANY OTHER GOVERNING CODE REQUIREMENTS.
3. VERIFY ALL UNDERGROUND UTILITIES BEFORE EXCAVATION.

STRUCTURAL NOTES

1. CODES AND STANDARDS  
THE PROJECT WAS DESIGNED IN ACCORDANCE WITH THE STANDARD BUILDING CODE 1991 EDITION.
2. FOUNDATION  
ALL SITE PREPARATION AND EXCAVATION WORK IS TO BE PERFORMED IN STRICT ACCORDANCE WITH THE RECOMMENDATIONS ON SOILS AND FOUNDATIONS INVESTIGATION PREPARED BY AN APPROVED TESTING LABORATORY PRIOR TO FOUNDATION WORK.  
BOTTOM OF FOOTINGS TO BEAR ON SOIL CAPABLE OF SAFELY SUPPORTING 2500 PSF.  
SOILS SUPPORTING ALL FOOTINGS MUST BE INSPECTED AND APPROVED BY A REGISTERED SOILS ENGINEER BEFORE COMMENCING WORK. APPROVAL IN WRITING MUST INDICATE THE SOIL IS ADEQUATE TO SAFELY SUSTAIN SPECIFIED SOIL BEARING PRESSURE.

STRUCTURAL NOTES:

3. CONCRETE  
ALL CONCRETE SHALL BE READY MIX, HAVE A MINIMUM COMPRESSIVE STRENGTH OF 2800 PSI @ 28 DAYS AND HAVE A MINIMUM OF 517 LBS. OF CEMENT PER CUBIC YARD.  
ALL THE CONCRETE WORK SHALL COMPLY WITH THE REQUIREMENTS OF THE ACI BUILDING CODE (ACI 318/LATEST EDITION), THE ACI DETAILING MANUAL (ACI 315/LATEST EDITION), AND THE SPECIFICATIONS FOR STRUCTURAL CONCRETE FOR BUILDINGS (ACI 301/LATEST EDITION)  
ALL REINFORCING STEEL SHALL BE MANUFACTURED FROM HIGH STRENGTH BILLET STEEL CONFORMING TO ASTM DESIGNATION A 615 GRADE 60. SPLICES TO LAP MIN 25". CONCRETE COVER MIN. 3" AGAINST EARTH @ SLAB  
THE PIT WALLS CAN BE CONSTRUCTED FROM MASONRY BRICK AS ALWAYS CONSULT YOUR CONTRACTOR TO ENSURE THE WALLS WILL STILL MEET THE CODES AND STRUCTURAL STANDARDS
4. MASONRY  
MASONRY UNITS SHALL BE ASTM C 90 GRADE N. ALL MORTAR SHALL BE TYPE S (OR TYPE M) IN ACCORDANCE WITH ASTM SPECIFICATION C270.  
PROVIDE HOT DIPPED GALVANIZED TRUSS TYPE HORIZONTAL REINFORCEMENT (MIN 9 GA.) AT 16" ON CENTER VERTICAL IN ALL MASONRY WALLS. PROVIDE DOVE TAIL SLOT ANCHORS AT CONCRETE COLUMNS.

MATERIAL: PER PRINT		DYNQJET RESEARCH 200 ARDEN DRIVE, BELGRADE MT 59714	
FINISH: AS SPECIFIED UNLESS OTHERWISE SPECIFIED: TOLERANCES			
DECIMAL X.XX ± 0.01 X.XXX ± 0.005	FRACTIONAL ± 1/16 ANGULAR ± 5"	224 CAR DYNAMOMETER FINISHED PIT DIMENSIONS	
DO NOT SCALE THIS DRAWING			
CREATED: DWK 09/16/98	LAST UPDATE: CTS 02/25/04	DESIGNED: XXX	APPROVED:
SIZE PART NO. D 98219103		REV 03	
SCALE: 1:15 RELEASE DATE:		SHEET 1 OF 2	

NO.	QTY.	PART NUMBER	DESCRIPTION OR NOMENCLATURE
1	X	XXXXXXXX	XXXXXXXXXXXX
PARTS LIST			
ALL IDEAS, DESIGNS, ARRANGEMENTS AND PLANS INDICATED OR REPRESENTED BY THIS DRAWING ARE OWNED BY DYNQJET RESEARCH, INC. AND WERE CREATED, EVOLVED AND DEVELOPED FOR USE ON AND IN CONNECTION WITH THE SPECIFIED PROJECT. NONE OF SUCH IDEAS, DESIGNS, ARRANGEMENTS OR PLANS SHALL BE USED BY OR DISCLOSED TO ANY PERSON, FIRM OR CORPORATION FOR ANY PURPOSE WHATSOEVER WITHOUT THE WRITTEN PERMISSION OF DYNQJET RESEARCH, INC.			

- NOTES, UNLESS OTHERWISE SPECIFIED:
1. ALL DIMENSIONS ARE IN DECIMAL INCHES.
  2. REMOVE ALL BURRS & SHARP EDGES.
  3. REMOVE ALL TOOLING MARKS.
  4. DIMENSIONS & TOLERANCES SHALL BE HELD AFTER PLATING OR FINISH.

REVISIONS				
ECR#	REV	DESCRIPTION	DATE	APPROVED
1807	02	ADDITION OF DYNO LOCATION PAGE	01/07/04	JFE
1878	03	ADDITION OF EXTENDED RETARDER PIT & NOTES	02/25/04	JFE

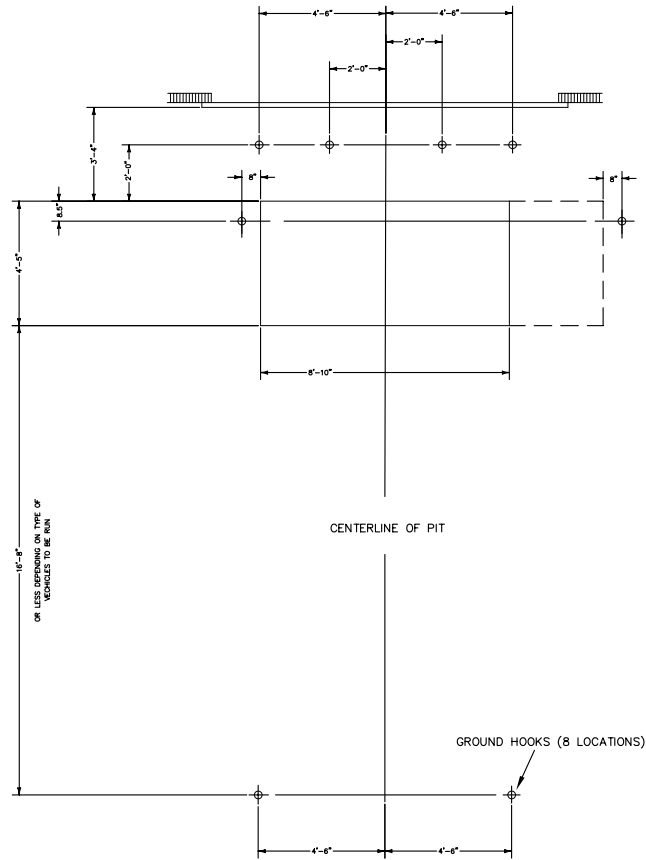

OPTIMUM REAR WHEEL INSTALLATION

THE TWO DYNO LOCATIONS SHOWN ABOVE ARE COMMONLY USED. IF NEITHER OF THESE CONFIGURATIONS WILL WORK FOR YOUR SITUATION PLEASE CONTACT DYNOJET. DYNOJET CAN HELP IN THE OPTIMUM LAYOUT FOR YOUR SITUATION AND NEEDS. MAKE SURE WHEN INSTALLING THE GROUND HOOKS, THE HOOK SWIVELS UP AND DOWN TOWARDS THE DYNO. THUS THE HOOKS ON EACH SIDE OF THE DYNO ARE TURNED 90° COMPARED TO THE HOOKS IN FRONT AND BACK OF THE DYNO.

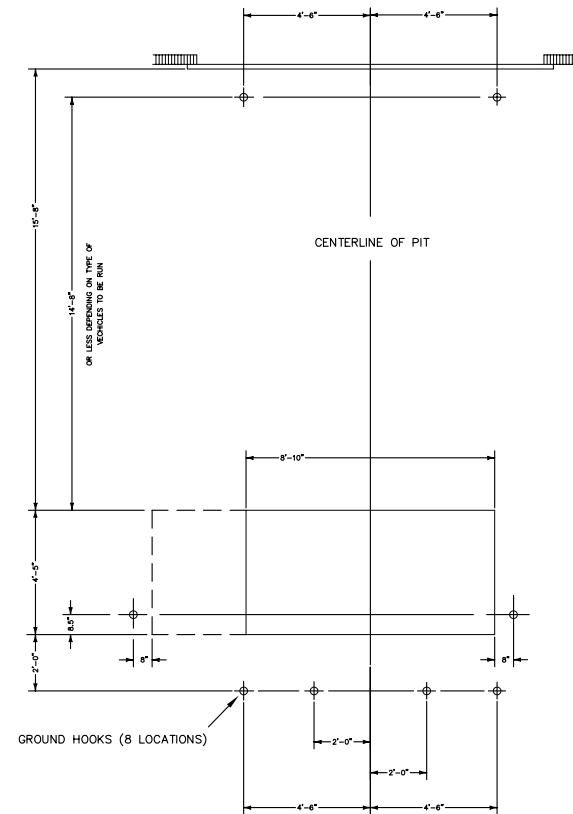

OPTIMUM FRONT WHEEL INSTALLATION

NO.	QTY.	PART NUMBER	DISCRPTION OR NOMENCLATURE
1	X	XXXXXXXX	XXXXXXXXXX
PARTS LIST			
ALL IDEAS, DESIGNS, ARRANGEMENTS AND PLANS INDICATED OR REPRESENTED BY THIS DRAWING ARE OWNED BY DYNOJET RESEARCH, INC. AND WERE CREATED, EVOLVED AND DEVELOPED FOR USE ON AND IN CONNECTION WITH THE SPECIFIED PROJECT. NONE OF SUCH IDEAS, DESIGNS, ARRANGEMENTS OR PLANS SHALL BE USED BY OR DISCLOSED TO ANY PERSON, FIRM OR CORPORATION FOR ANY PURPOSE WHATSOEVER WITHOUT THE WRITTEN PERMISSION OF DYNOJET RESEARCH, INC.			
DYNOJET RESEARCH, INC.			

MATERIAL:	PER PRINT
FINISH:	AS SPECIFIED
UNLESS OTHERWISE SPECIFIED:	
TOLERANCES	
DECIMAL	FRACTIONAL
X.XX ± 0.01	± 1/16
X.XXX ± 0.005	ANGULAR
	± 5°
DO NOT SCALE THIS DRAWING	
CREATED:	CTS 01/07/04
LAST UPDATE:	CTS 02/25/04
DESIGNED:	DWK
APPROVED:	

## DYNOJET RESEARCH

200 ARDEN DRIVE, BELGRADE MT 59714

224 CAR DYNAMOMETER  
DYNO LOCATION GUIDE

SIZE	PART NO.	REV
D	98219103	03
SCALE: X:X	RELEASE DATE:	SHEET 2 OF 2

REVISIONS				
ECR#	REV	DESCRIPTION	DATE	APPROVED
1807	02	ADDITION OF PAGES 5 & 6	01/07/04	JFE
1878	03	ADDITION OF EXTENDED RETARDER PIT & NOTES	02/25/04	JFE

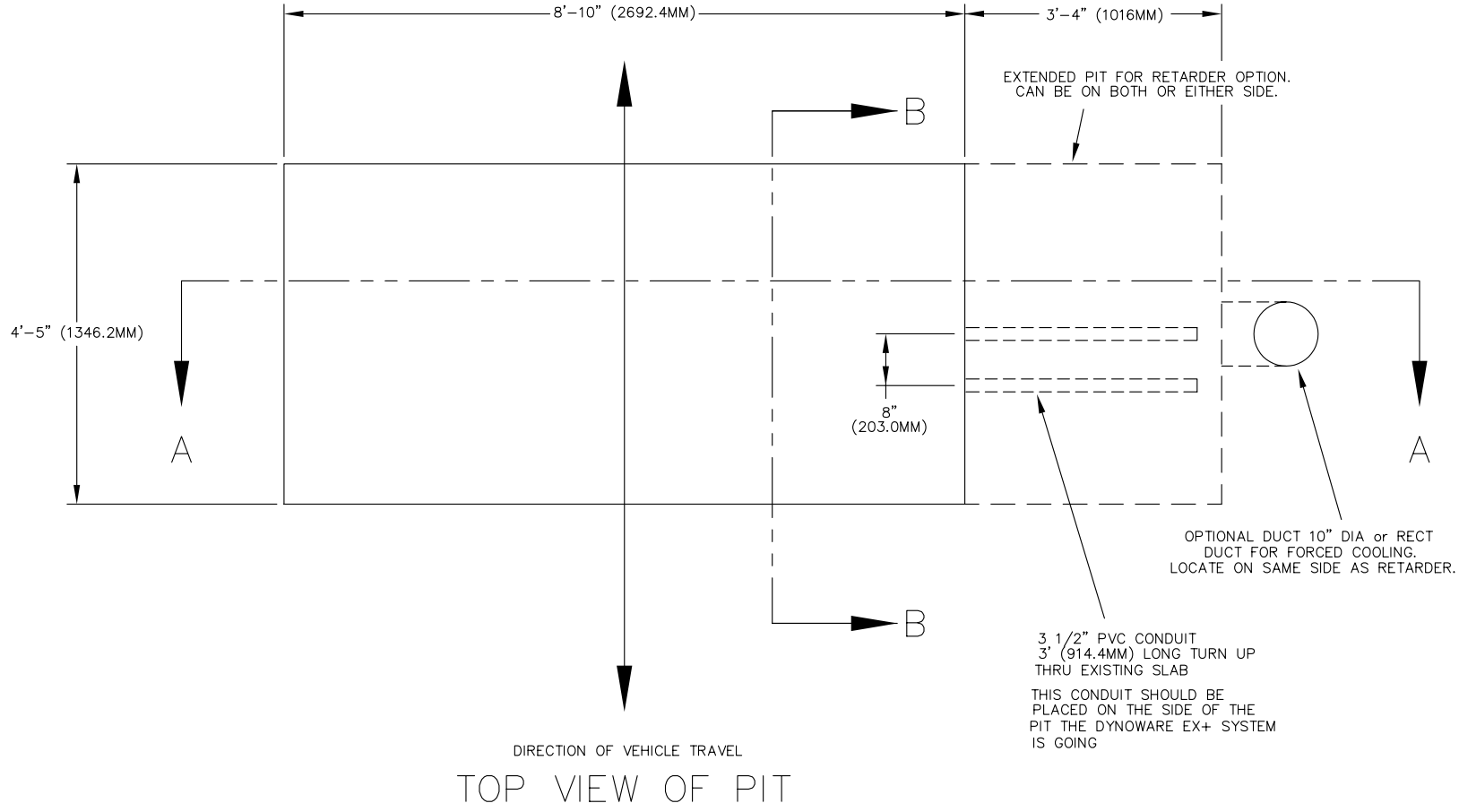

MATERIAL:	N/A
FINISH:	N/A
UNLESS OTHERWISE SPECIFIED: TOLERANCES	
DECIMAL	FRACTIONAL
X.XX ± 0.01	± 1/16
X.XXX ± 0.005	ANGULAR ± 5°
DO NOT SCALE THIS DRAWING	
CREATED:	CTS 05/16/02
LAST UPDATE:	CTS 02/25/04
DESIGNED:	JFE
APPROVED:	

<b>DYNOJET RESEARCH</b>	
200 ARDEN DRIVE, BELGRADE MT 59714	
224 CAR DYNAMOMETER TOP VIEW	
SIZE	PART NO.
A	98219103
REV	03
SCALE: X:X	RELEASE DATE:
	SHEET 1 OF 6

ALL IDEAS, DESIGNS, ARRANGEMENTS AND PLANS INDICATED OR REPRESENTED BY THIS DRAWING ARE OWNED BY DYNOJET RESEARCH INC. AND WERE CREATED, EVOLVED AND DEVELOPED FOR USE ON AND IN CONNECTION WITH THE SPECIFIED PROJECT. NONE SUCH IDEAS, DESIGNS, ARRANGEMENTS OR PLANS SHALL BE USED BY OR DISCLOSED TO ANY PERSON, FIRM, OR CORPORATION FOR ANY PURPOSE WHATSOEVER WITHOUT THE WRITTEN PERMISSION OF DYNOJET RESEARCH, INC.

DYNOJET RESEARCH, INC.

REVISIONS				
ECR#	REV	DESCRIPTION	DATE	APPROVED
1807	02	ADDITION OF PAGE 5 & 6	01/07/04	JFE
1878	03	ADDITION OF EXTENDED RETARDER PIT & NOTES	02/25/04	JFE

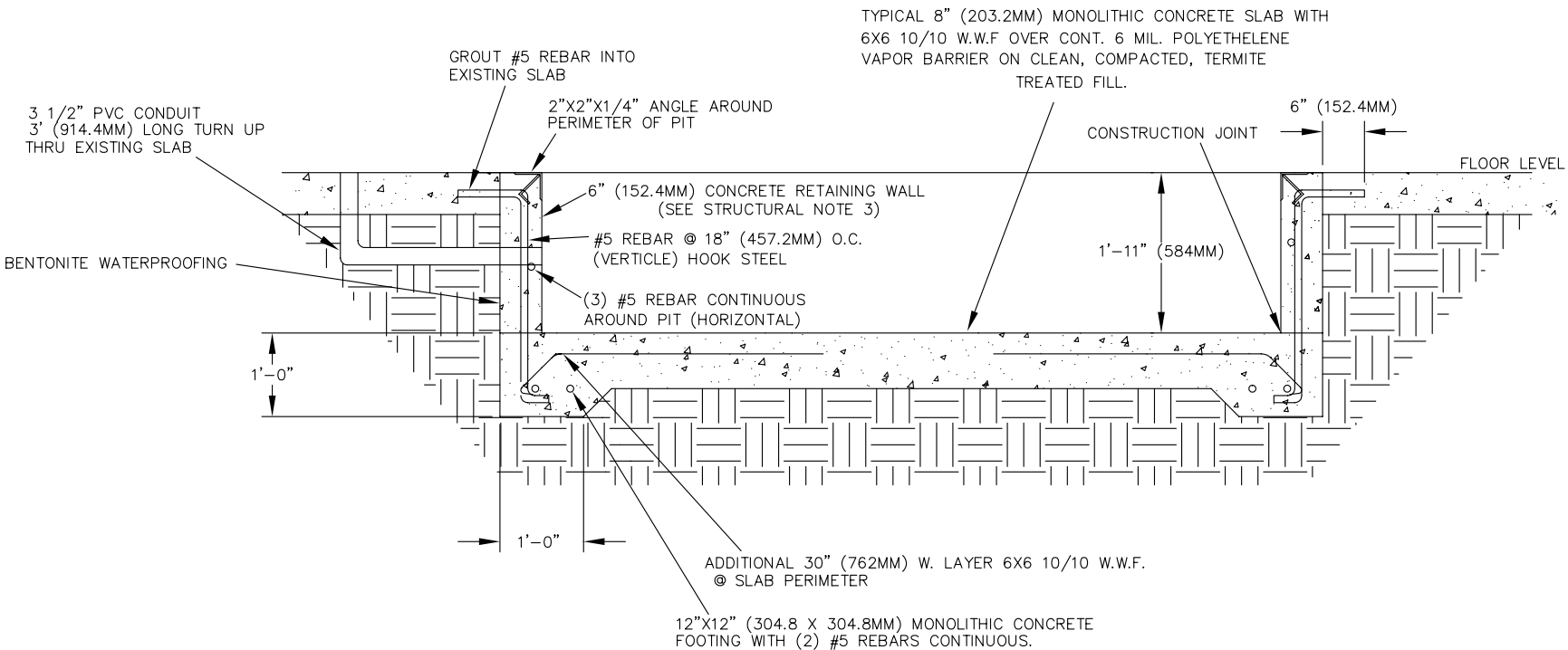

SECTION A-A

MATERIAL:	N/A		
FINISH:	N/A		
UNLESS OTHERWISE SPECIFIED: TOLERANCES			
DECIMAL	FRACTIONAL		
X.XX ± 0.01	± 1/16		
X.XXX ± 0.005	ANGULAR		
	± 5°		
DO NOT SCALE THIS DRAWING			
CREATED:	CTS	05/16/02	
LAST UPDATE:	CTS	02/25/04	
DESIGNED:	JFE		
APPROVED:			

<b>DYNOJET RESEARCH</b>	
200 ARDEN DRIVE, BELGRADE MT 59714	
224 CAR DYNAMOMETER SECTION A-A	
SIZE	PART NO.
A	98219103
REV	03
SCALE: X:X	RELEASE DATE:
	SHEET 2 OF 6

ALL IDEAS, DESIGNS, ARRANGEMENTS AND PLANS INDICATED OR REPRESENTED BY THIS DRAWING ARE OWNED BY DYNOJET RESEARCH INC. AND WERE CREATED, EVOLVED AND DEVELOPED FOR USE ON AND IN CONNECTION WITH THE SPECIFIED PROJECT. NONE SUCH IDEAS, DESIGNS, ARRANGEMENTS OR PLANS SHALL BE USED BY OR DISCLOSED TO ANY PERSON, FIRM, OR CORPORATION FOR ANY PURPOSE WHATSOEVER WITHOUT THE WRITTEN PERMISSION OF DYNOJET RESEARCH, INC.

DYNOJET RESEARCH, INC.

REVISIONS				
ECR#	REV	DESCRIPTION	DATE	APPROVED
1807	02	ADDITION OF PAGE 5 & 6	01/07/04	JFE
1878	03	ADDITION OF EXTENDED RETARDER PIT & NOTES	02/25/04	JFE

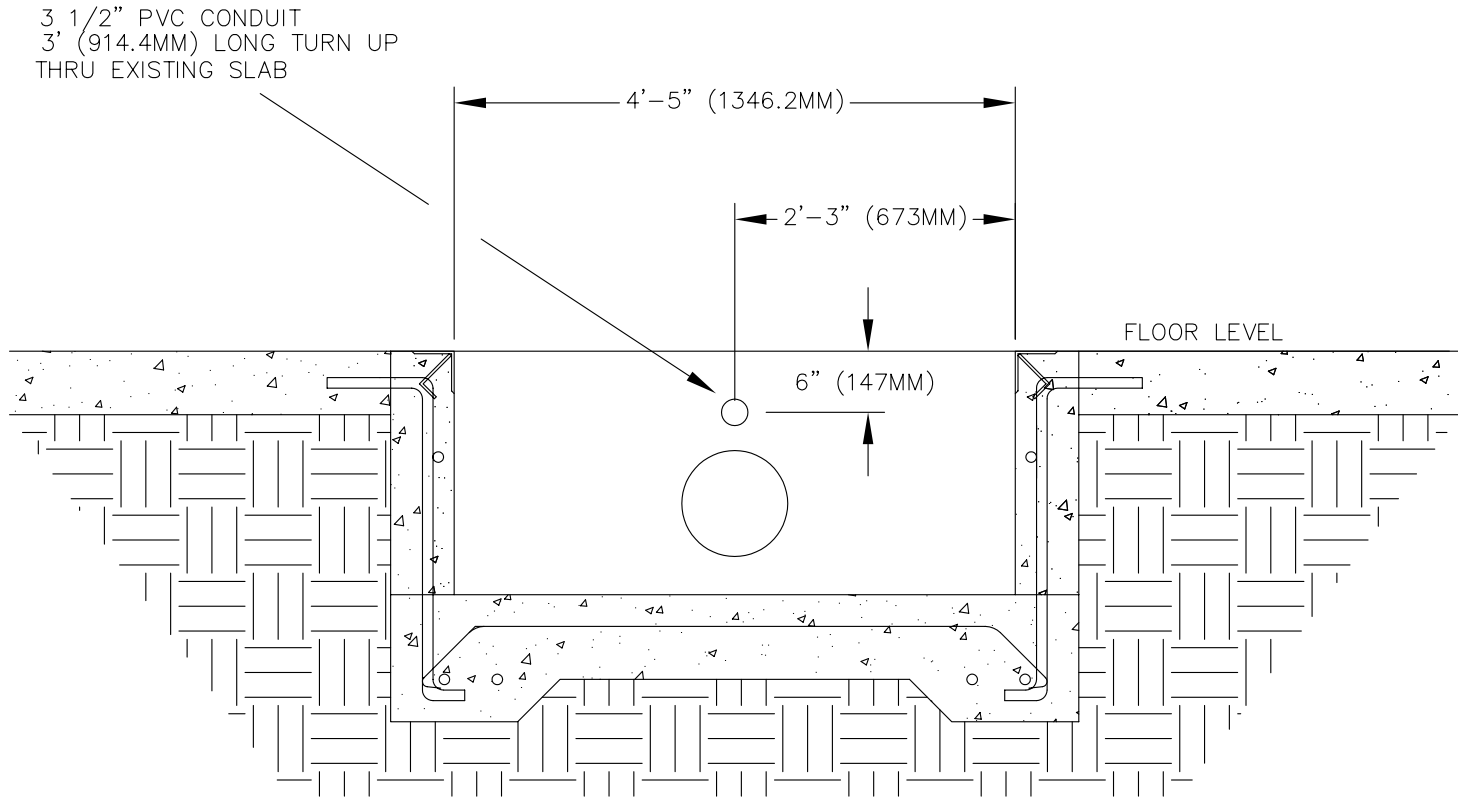

SECTION B-B

MATERIAL: N/A		<b>DYNOJET RESEARCH</b> 200 ARDEN DRIVE, BELGRADE MT 59714	
FINISH: N/A			
UNLESS OTHERWISE SPECIFIED: TOLERANCES		224 CAR DYNAMOMETER SECTION B-B	
DECIMAL	FRACTIONAL		
X.XX ± 0.01	± 1/16		
X.XXX ± 0.005	ANGULAR ± 5°		
DO NOT SCALE THIS DRAWING			
CREATED:	CTS 05/16/02		
LAST UPDATE:	CTS 02/25/04	SIZE	PART NO.
DESIGNED:	JFE	A	98219103
APPROVED:		SCALE: X:X	RELEASE DATE:
		SHEET 3	OF 6
		REV	03

ALL IDEAS, DESIGNS, ARRANGEMENTS AND PLANS INDICATED OR REPRESENTED BY THIS DRAWING ARE OWNED BY DYNOJET RESEARCH INC. AND WERE CREATED, EVOLVED AND DEVELOPED FOR USE ON AND IN CONNECTION WITH THE SPECIFIED PROJECT. NONE SUCH IDEAS, DESIGNS, ARRANGEMENTS OR PLANS SHALL BE USED BY OR DISCLOSED TO ANY PERSON, FIRM, OR CORPORATION FOR ANY PURPOSE WHATSOEVER WITHOUT THE WRITTEN PERMISSION OF DYNOJET RESEARCH, INC.

DYNOJET RESEARCH, INC.

REVISIONS				
ECR#	REV	DESCRIPTION	DATE	APPROVED
1807	02	ADDITION OF PAGE 5 & 6	01/07/04	JFE
1878	03	ADDITION OF EXTENDED RETARDER PIT & NOTES	02/25/04	JFE

**NOTES:**

1. ALL DIMENSIONS ARE NOMINAL TO FACE OF MASONRY OR TO FACE OF METAL STUD.
2. ALL WORK SHALL BE IN ACCORDANCE WITH LOCAL AND STATE AND OR ANY OTHER GOVERNING CODE REQUIREMENTS.
3. VERIFY ALL UNDERGROUND UTILITIES BEFORE EXCAVATION.

**STRUCTURAL NOTES**

1. CODES AND STANDARDS

THE PROJECT WAS DESIGNED IN ACCORDANCE WITH THE STANDARD BUILDING CODE 1991 EDITION.

2. FOUNDATION

ALL SITE PREPARATION AND EXCAVATION WORK IS TO BE PERFORMED IN STRICT ACCORDANCE WITH THE RECOMMENDATIONS ON SOILS AND FOUNDATIONS INVESTIGATION PREPARED BY AN APPROVED TESTING LABORATORY PRIOR TO FOUNDATION WORK.

BOTTOM OF FOOTINGS TO BEAR ON SOIL CAPABLE OF SAFELY SUPPORTING 2500 PSF.

SOILS SUPPORTING ALL FOOTINGS MUST BE INSPECTED AND APPROVED BY A REGISTERED SOILS ENGINEER BEFORE COMMENCING WORK. APPROVAL IN WRITING MUST INDICATE THE SOIL IS ADEQUATE TO SAFELY SUSTAIN SPECIFIED SOIL BEARING PRESSURE.

**STRUCTURAL NOTES:**

3. CONCRETE

ALL CONCRETE SHALL BE READY MIX, HAVE A MINIMUM COMPRESSIVE STRENGTH OF 2800 PSI @ 28 DAYS AND HAVE A MINIMUM OF 517 LBS. OF CEMENT PER CUBIC YARD.

ALL THE CONCRETE WORK SHALL COMPLY WITH THE REQUIREMENTS OF THE ACI BUILDING CODE (ACI 318/LATEST EDITION), THE ACI DETAILING MANUAL (ACI 315/LATEST EDITION), AND THE SPECIFICATIONS FOR STRUCTURAL CONCRETE FOR BUILDINGS (ACI 301/LATEST EDITION)

ALL REINFORCING STEEL SHALL BE MANUFACTURED FROM HIGH STRENGTH BILLET STEEL CONFORMING TO ASTM DESIGNATION A 615 GRADE 60. SPLICES TO LAP MIN 25". CONCRETE COVER MIN. 3" AGAINST EARTH @ SLAB

THE PIT WALLS CAN BE CONSTRUCTED FROM MASONRY BRICK AS ALWAYS CONSULT YOUR CONTRACTOR TO ENSURE THE WALLS WILL STILL MEET THE CODES AND STRUCTURAL STANDARDS

4. MASONRY

MASONRY UNITS SHALL BE ASTM C 90 GRADE N. ALL MORTAR SHALL BE TYPE S (OR TYPE M) IN ACCORDANCE WITH ASTM SPECIFICATION C270.

PROVIDE HOT DIPPED GALVANIZED TRUSS TYPE HORIZONTAL REINFORCEMENT (MIN 9 GA.) AT 16" ON CENTER VERTICFAL IN ALL MASONRY WALLS. PROVIDE DOVE TAIL SLOT ANCHORS AT CONCRETE COLUMNS.

MATERIAL: N/A		<b>DYNOJET RESEARCH</b> 200 ARDEN DRIVE, BELGRADE MT 59714	
FINISH: N/A			
UNLESS OTHERWISE SPECIFIED: TOLERANCES		224 CAR DYNAMOMETER NOTES	
DECIMAL X.XX ± 0.01 X.XXX ± 0.005	FRACTIONAL ± 1/16 ANGULAR ± 5°		
DO NOT SCALE THIS DRAWING			
CREATED: CTS	05/16/02		
LAST UPDATE: CTS	02/25/04	SIZE	PART NO.
DESIGNED: JFE		A	98219103
APPROVED:		SCALE: X:X	RELEASE DATE:
			SHEET 4 OF 6
			REV 03

ALL IDEAS, DESIGNS, ARRANGEMENTS AND PLANS INDICATED OR REPRESENTED BY THIS DRAWING ARE OWNED BY DYNOJET RESEARCH INC. AND WERE CREATED, EVOLVED AND DEVELOPED FOR USE ON AND IN CONNECTION WITH THE SPECIFIED PROJECT. NONE SUCH IDEAS, DESIGNS, ARRANGEMENTS OR PLANS SHALL BE USED BY OR DISCLOSED TO ANY PERSON, FIRM, OR CORPORATION FOR ANY PURPOSE WHATSOEVER WITHOUT THE WRITTEN PERMISSION OF DYNOJET RESEARCH, INC..

DYNOJET RESEARCH, INC.

NOTES, UNLESS OTHERWISE SPECIFIED

1. ALL DIMENSIONS ARE IN DECIMAL INCHES.
2. REMOVE ALL BURRS & SHARP EDGES.
3. REMOVE ALL TOOLING MARKS.
4. DIMENSIONS & TOLERANCES SHALL BE HELD AFTER PLATING OR FINISH.

REVISIONS				
ECR#	REV	DESCRIPTION	DATE	APPROVED
1807	02	ADDITION OF PAGE 5 & 6	01/07/04	JFE
1878	03	ADDITION OF EXTENDED RETARDER PIT & NOTES	02/25/04	JFE

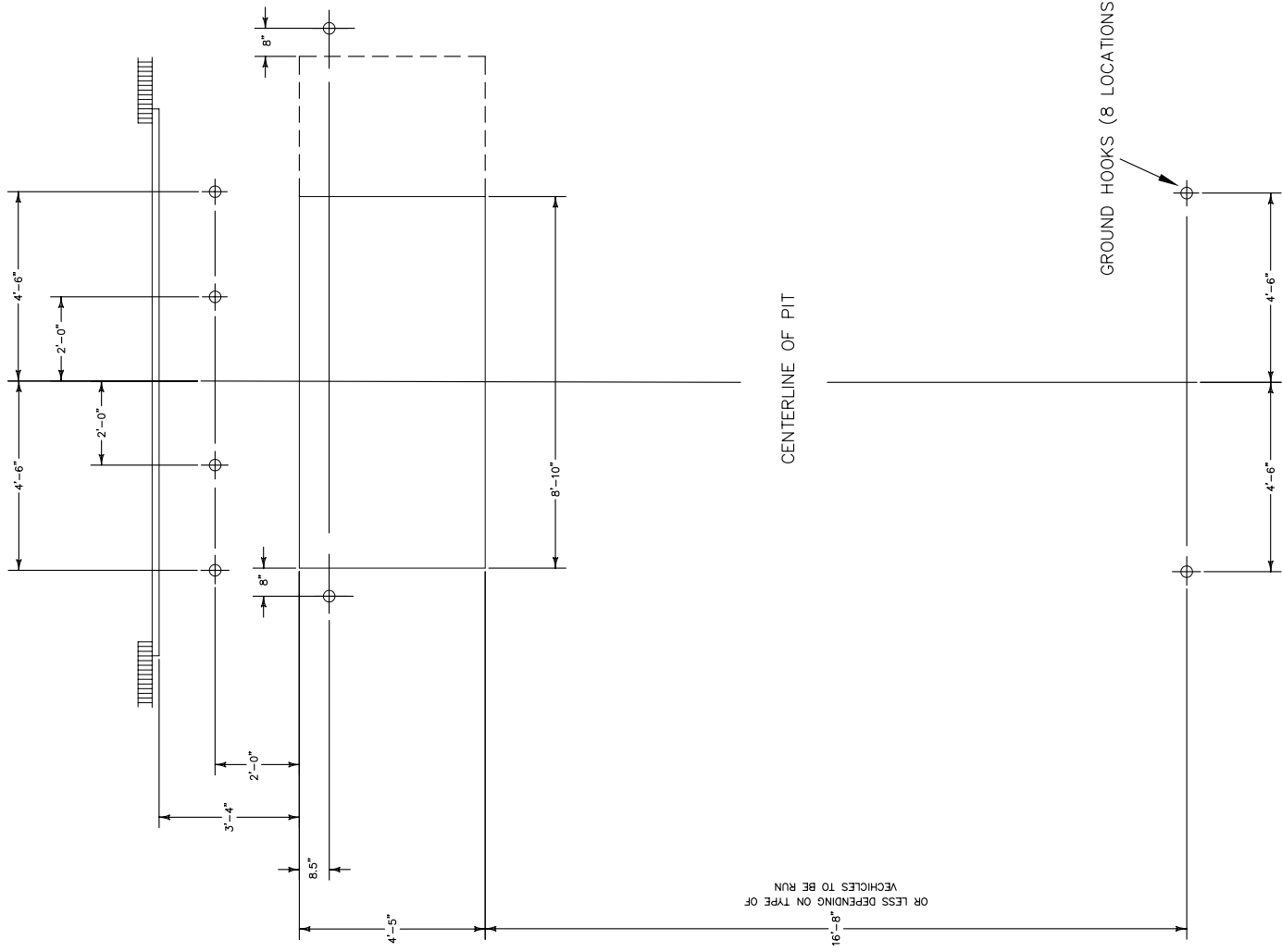

OPTIMUM REAR WHEEL INSTALLATION

THE TWO DYNO LOCATIONS SHOWN ABOVE ARE COMMONLY USED. IF NEITHER OF THESE CONFIGURATIONS WILL WORK FOR YOUR SITUATION PLEASE CONTACT DYNOJET. DYNOJET CAN HELP IN THE OPTIMUM LAYOUT FOR YOUR SITUATION AND NEEDS. MAKE SURE WHEN INSTALLING THE GROUND HOOKS, THE HOOK SWIVELS UP AND DOWN TOWARDS THE DYNO. THUS THE HOOKS ON EACH SIDE OF THE DYNO ARE TURNED 90° COMPARED TO THE HOOKS IN FRONT AND BACK OF THE DYNO.

OR LESS DEPENDING ON TYPE OF VEHICLES TO BE RUN

MATERIAL:	PER PRINT
FINISH:	AS SPECIFIED
UNLESS OTHERWISE SPECIFIED: TOLERANCES	
DECIMAL	FRACTIONAL
X.XX ± 0.01	± 1/16
X.XXX ± 0.005	ANGULAR ± 5°
DO NOT SCALE THIS DRAWING	
CREATED:	CTS 01/07/04
LAST UPDATE:	CTS 02/25/04
DESIGNED:	JFE
APPROVED:	

<b>DYNOJET RESEARCH</b>	
200 ARDEN DRIVE, BELGRADE MT 59714	
224 CAR DYNAMOMETER REAR-WHEEL INSTALLATION	
SIZE	PART NO.
A	98219103
REV	03
SCALE: X: X	RELEASE DATE:
SHEET 5	OF 6

ALL IDEAS, DESIGNS, ARRANGEMENTS AND PLANS INDICATED OR REPRESENTED BY THIS DRAWING ARE OWNED BY DYNOJET RESEARCH INC. AND WERE CREATED, EVOLVED AND DEVELOPED FOR USE ON AND IN CONNECTION WITH THE SPECIFIED PROJECT. NONE SUCH IDEAS, DESIGNS, ARRANGEMENTS OR PLANS SHALL BE USED BY OR DISCLOSED TO ANY PERSON, FIRM, OR CORPORATION FOR ANY PURPOSE WHATSOEVER WITHOUT THE WRITTEN PERMISSION OF DYNOJET RESEARCH, INC.

DYNOJET RESEARCH, INC.

NOTES, UNLESS OTHERWISE SPECIFIED

1. ALL DIMENSIONS ARE IN DECIMAL INCHES.
2. REMOVE ALL BURRS & SHARP EDGES.
3. REMOVE ALL TOOLING MARKS.
4. DIMENSIONS & TOLERANCES SHALL BE HELD AFTER PLATING OR FINISH.

REVISIONS				
ECR#	REV	DESCRIPTION	DATE	APPROVED
1807	02	ADDITION OF PAGE 5 & 6	01/07/04	JFE
1878	03	ADDITION OF EXTENDED RETARDER PIT & NOTES	02/25/04	JFE

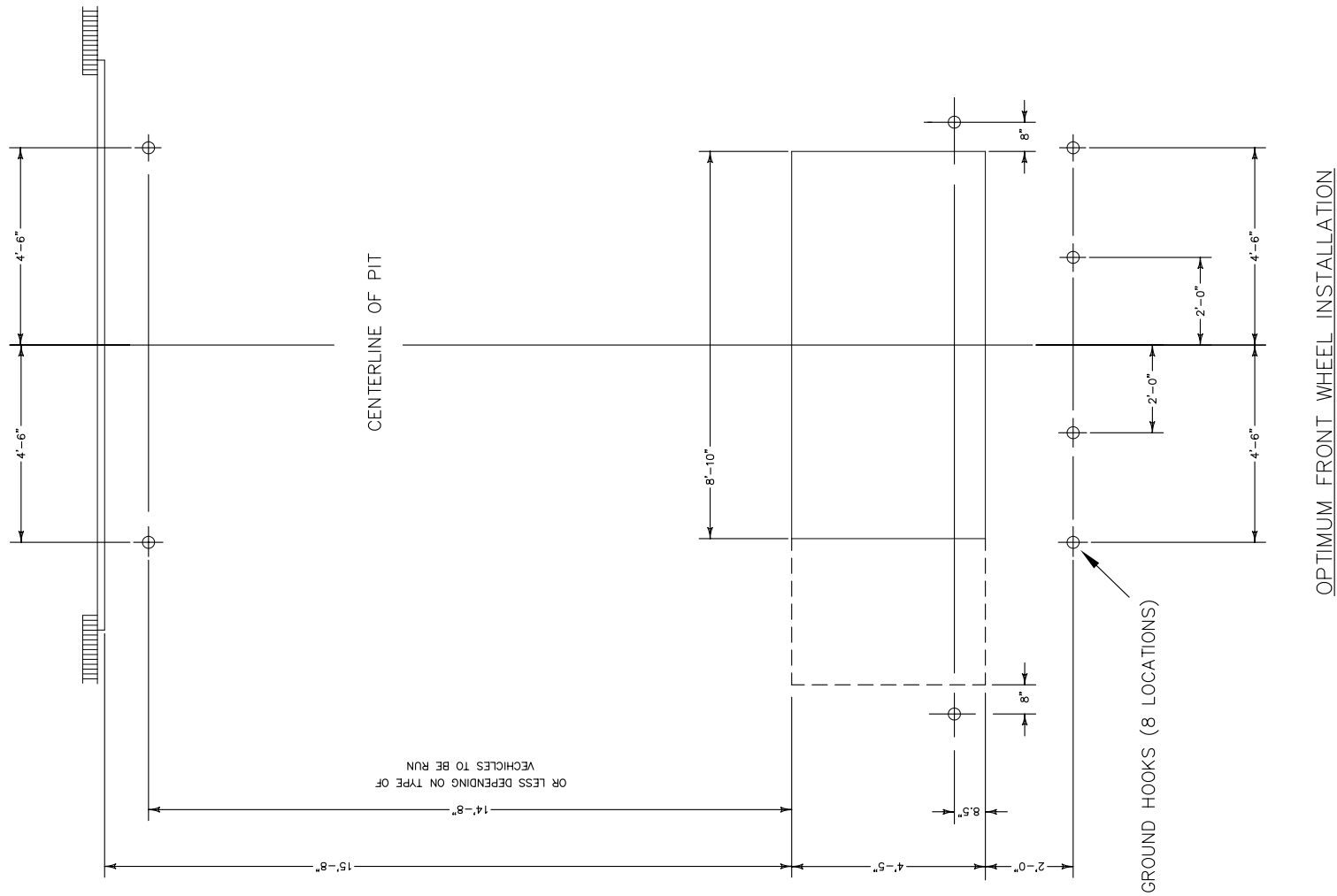

OR LESS DEPENDING ON TYPE OF VEHICLES TO BE RUN

GROUND HOOKS (8 LOCATIONS)

MATERIAL:	PER PRINT
FINISH:	AS SPECIFIED
UNLESS OTHERWISE SPECIFIED:	
TOLERANCES	
DECIMAL	FRACTIONAL
X.XX ± 0.01	± 1/16
X.XXX ± 0.005	ANGULAR
	± 5°
DO NOT SCALE THIS DRAWING	
CREATED:	CTS 01/07/04
LAST UPDATE:	CTS 02/25/04
DESIGNED:	JFE
APPROVED:	

<b>DYNOJET RESEARCH</b>	
200 ARDEN DRIVE, BELGRADE MT 59714	
224 CAR DYNAMOMETER FRONT WHEEL INSTALLATION	
SIZE	PART NO.
A	98219103
REV	03
SCALE: X:X	RELEASE DATE:
SHEET 6	OF 6

ALL IDEAS, DESIGNS, ARRANGEMENTS AND PLANS INDICATED OR REPRESENTED BY THIS DRAWING ARE OWNED BY DYNOJET RESEARCH INC. AND WERE CREATED, EVOLVED AND DEVELOPED FOR USE ON AND IN CONNECTION WITH THE SPECIFIED PROJECT. NONE SUCH IDEAS, DESIGNS, ARRANGEMENTS OR PLANS SHALL BE USED BY OR DISCLOSED TO ANY PERSON, FIRM, OR CORPORATION FOR ANY PURPOSE WHATSOEVER WITHOUT THE WRITTEN PERMISSION OF DYNOJET RESEARCH, INC.

DYNOJET RESEARCH, INC.